

SERIES 3100

Screw-less connectors on both appliance and installation side used for making fast connection and disconnection.



Raw materials

Moulding: Polyamide 6.6. Cream colour. V0 (according to UL94).

Insert: Steel.



Glow-wire test 960°C according to EN 60695-2-11

Technical features according to EN 60998

According to clause 4.7 UNE-EN 60598-1. Luminaries. General requirements and tests.

Compatible with automatic assembly robots.

Printing upon request.

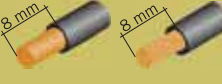
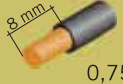
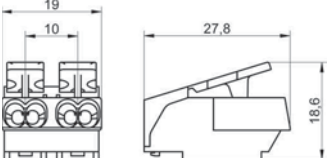
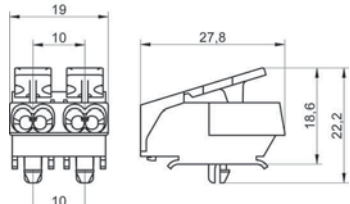
3102	Standard printing N L	Voltage 450V	Current rating 24A	110°C	500 pcs.	265x165x230 mm	3,2 Kg
Appliance side:		Installation side:		Capacitor:			
							
		3102 A - fixing pins					

ST/3 Strain relief clamp (for clamping and fixing of external conductors in lighting fixtures).





Compatible with all references except from **3102**



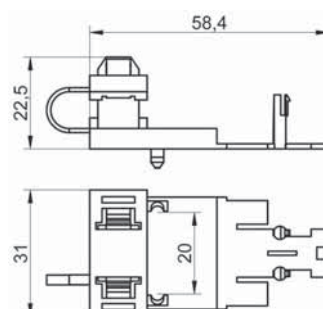







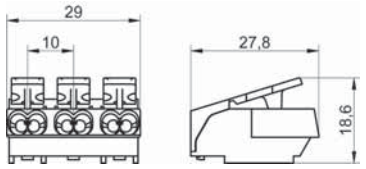





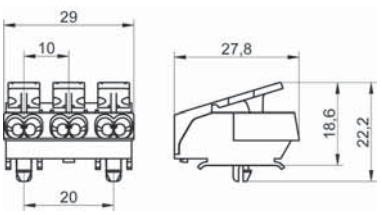

Polyamide 6. Natural colour



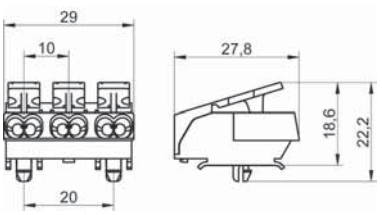











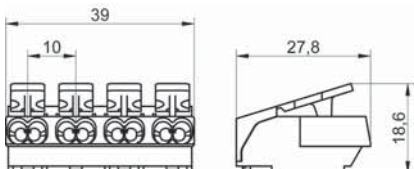





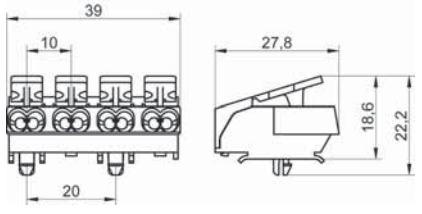

500 pcs. 265x165x230 mm

2,7 Kg

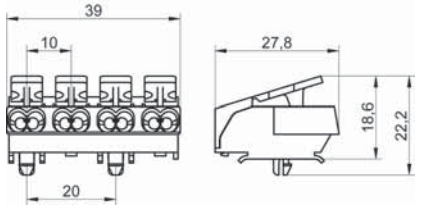













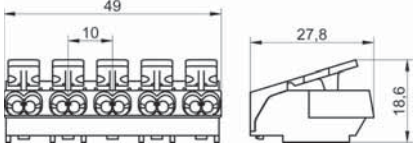





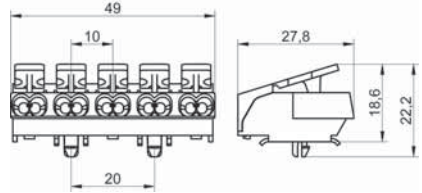

3103	Standard printing	N  L	Voltage	450V	Current rating	24A	 110°C
Appliance side:	Installation side:		Capacitor:				
 2 x 2,5 mm ² / 0,75 mm ²	 1 x 2,5 mm ² / 1 mm ²		 0,75 mm ² / 0,5 mm ²				

3103			3103 TI / 3103 A TI - rapid earth tag 				
 300 pcs.	265x165x230 mm	 3 Kg	 300 pcs. 265x165x230 mm  3,2 Kg				
3103 A - fixing pins 			3103 TT / 3103 A TT - screw earth tag 				
 300 pcs.	265x165x230 mm	 3 Kg	 250 pcs. 265x165x230 mm  2,4 Kg				
3103 A - fixing pins 			3103 TA / 3103 A TA - clamping earth tag 				
 300 pcs.	265x165x230 mm	 3 Kg	 250 pcs.	265x165x230 mm	 2,6 Kg		

3104	Standard printing	N  L1 L2	Voltage	450V	Current rating	24A	 110°C
Appliance side:	Installation side:		Capacitor:				
 2 x 2,5 mm ² / 0,75 mm ²	 1 x 2,5 mm ² / 1 mm ²		 0,75 mm ² / 0,5 mm ²				
3104			3104 TI / 3104 A TI - rapid earth tag 				
 250 pcs.	265x165x230 mm	 3,3 Kg	 250 pcs. 265x165x230 mm  3,5 Kg				
3104 A - fixing pins 			3104 TT / 3104 A TT - screw earth tag 				
 250 pcs.	265x165x230 mm	 3,3 Kg	 200 pcs. 265x165x230 mm  2,6 Kg				
3104 A - fixing pins 			3104 TA / 3104 A TA - clamping earth tag 				
 250 pcs.	265x165x230 mm	 3,3 Kg	 200 pcs.	265x165x230 mm	 2,8 Kg		

SERIES 3100

3105	Standard printing L3 N  L1 L2	Voltage 450V	Current rating 24A	 110°C
Appliance side:  2 x 0,75 mm ² / 0,75 mm ²	Installation side:  2 x 0,75 mm ² / 0,75 mm ²	Capacitor:  0,75 mm ² / 0,5 mm ²		
3105 	3105 TI / 3105 A TI - rapid earth tag 			
 200 pcs. 265x165x230 mm  3,3 Kg	 200 pcs. 265x165x230 mm  3,5 Kg			
3105 A - fixing pins 	3105 TT / 3105 A TT - screw earth tag 			
 200 pcs. 265x165x230 mm  3,3 Kg	 150 pcs. 265x165x230 mm  4,1 Kg			
	3105 TA / 3105 A TA - clamping earth tag 			
 200 pcs. 265x165x230 mm  3,3 Kg	 150 pcs. 265x165x230 mm  4,3 Kg			

Additional technical data on fixing systems at www.tekox.es or calling TEKOX.

