

S4030



order code

model	lamp type	lamp holder	order code
S4030 MH 2000W	tubular	E40	S4030-M2000
accessories	housing material	IP rated	order code
remote control gear	die-cast aluminium	IP65	S5200 UA-M2000

note : S4030 narrow beam type and medium beam type floodlights are available upon request • specification is subject to change without prior notice

NIKON®
Light up the World

220 - 240V 50Hz E40



IP65



CE

dimension

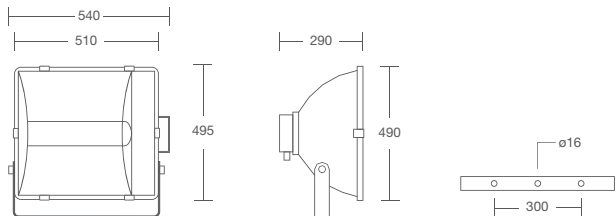

photometric curve

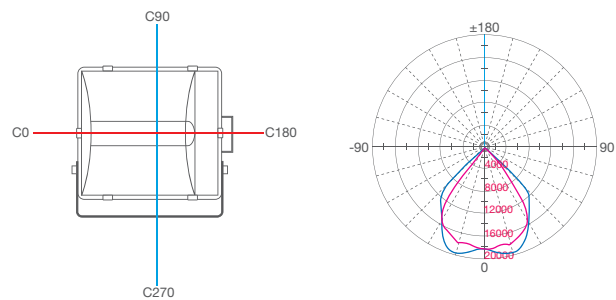

note : photometric result tested based on 180000lm MH 2000W clear tube

accessories

S5200-UA

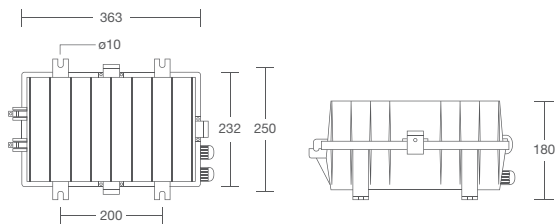

technical data

ingress protection • IP65 (lamp fitting)
voltage • 220 - 240 Vac 50 Hz
lamp wattage • MH 2000W
holder type • E40 ceramic lamp holder
maximum weight • 12 kg
control gear weight • 19.5 kg
colour of housing • black



features

housing

- high pressure aluminium die-cast housing

reflector

- high purity anodized hammered finish aluminium reflector

glass

- frameless thermal resistant tempered glass

mounting bracket

- steel mounting bracket coated with epoxy powder

rear cover

- easy access to the lamp from rear without removing the front glass