

## S2000



### order code

model	lamp type	lamp holder	order code
S2000 SY MH 250W (2.1A)	tubular	E40	S2000-M0250
S2000 SY MH 400W	tubular	E40	S2000-M0400
S2000 SY HPS 250W	tubular	E40	S2000-S0250
S2000 SY HPS 400W	tubular	E40	S2000-S0400

note : S2000 asymmetrical type floodlight is available upon request • specification is subject to change without prior notice

### dimension

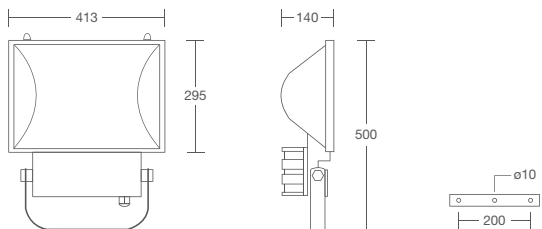

### photometric curve

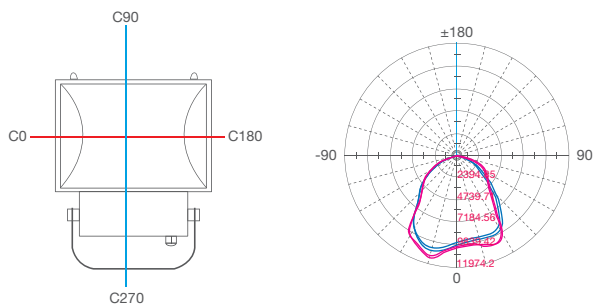

note : photometric result tested based on 32000lm MH 400W clear tube

### features

#### electrical system

- built-in control gear suitable for HID lamps from 250W - 450W

#### housing

- high pressure aluminium die-cast housing

#### reflector

- high purity anodized hammered finish aluminium reflector

#### glass

- thermal resistant tempered glass

#### mounting bracket

- steel mounting bracket coated with epoxy powder

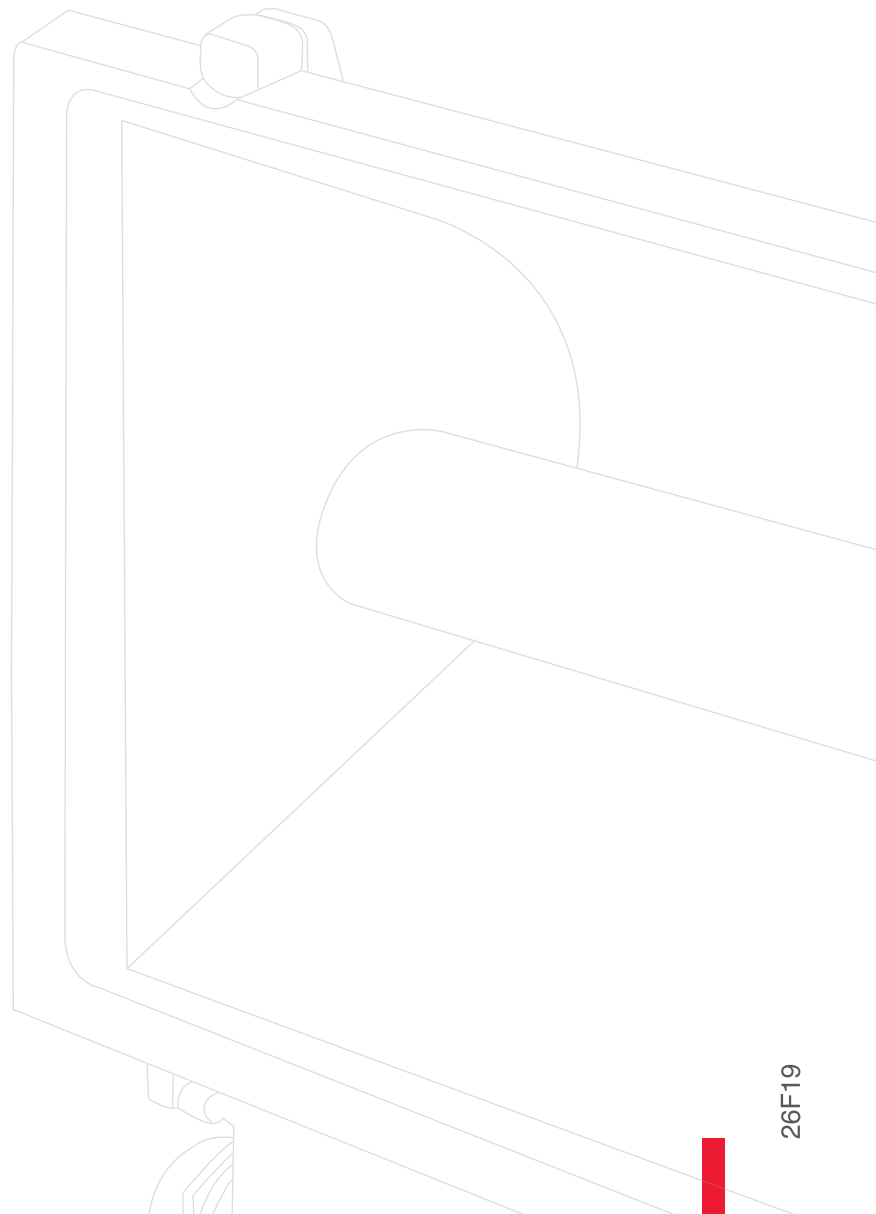

### technical data

- ingress protection • IP65
- voltage • 220 - 240 Vac 50 Hz
- lamp wattage • 250W - 400W
- holder type • E40 ceramic lamp holder
- maximum weight • 9 kg
- colour of housing • black